

Quality Product

All Manufactured modules are tested 100% by EL (Electroluminescence) during the Production Process & Free from micro cracks.

Our high-performance modules are highly efficient, reliable and provide optimal output.

The company manufactures solar modules in compliance with global standard including MNRE, IEC 61215, 61730-1, 61730-2, 61701, UL 1703, UL 61730, ISO 9001:2008 & ISO 14001:2004 & 18001:2007.

High Efficiency .

High Module efficiency is obtaining top performance even in diffused light conditions.

We are leaders in providing our customers with maximum sunlight conversion.

Application Possibilities

Residential and Commercial rooftops, Car ports, Solar Farming, Balconies, Awnings, Street lights, Fences, and Canopies.

Our Team

We have a team of qualified experts and engineers making sure that modules produce maximum power. We pride ourselves in caring for each individual customer needs with detailed attention. Our end goal is to give a highly efficient product with exceptional customer service.

Guarantee

Our product is durable and has 25 years performance warranty. Integrated manufacturing of cells & modules in production line guarantees optimum performance.

US OFFICE:

Sonali Energiees USA LLC
 111 Charlotte Place Suite 101A
 Englewood Cliffs, NJ 07632
 Office Tel: 201-568-1424
 info@sonalisolar.com



Electric Performance Parameter

| | |
|-----------------------------------|---------|
| Model | SS 100W |
| Nominal Maximum Power (Pmax/W) | 100 |
| Optimum Operating Voltage (Vmp/V) | 17.9 |
| Optimum Operating Current (Imp/A) | 5.72 |
| Open Circuit Voltage (Voc/V) | 21.6 |
| Short Circuit Current (Isc/A) | 6.24 |

- * Measurement Power Tolerance on Power 0 / +%
- * Under Standard Test Conditions (STC) of irradiance of 1000W/m²
- * Spectrum AM 1.5 and cell temperature of 25 °C
- * Normal Operating cell Temperature (NOCT) of irradiance of 800W/m², 43± 2° C

Mechanical Parameter

| | |
|------------------------------|---|
| Module Dimensions | 920 X 510 X 30 mm / 36.25 X 20.125 X 1.18 inch |
| Weight | 7.5 kgs / 16.5lbs |
| Cell Size (Monocrystalline) | 158.75x83 mm / 6.25x3.27 inch |
| No Of Cell | 33 (3 X 11) |
| Junction Box | PV-LH0801/ IP65 with Bypass diodes |
| Solar Cable | 900mm (35.43 inch) length with 4mm ² |
| Connectors | Mc4 compatible or IP67 rated |
| Glass (Tempered & Low Iron) | 3.2mm (0.13in) |
| Encapsulate | EVA |
| Back Cover | Composite Sheet |
| Frame | Anodized Aluminum Alloy |

Temperature Coefficient

| | |
|------------------------|------------|
| Coefficient of Current | +0.035% /K |
| Coefficient of Voltage | -0.351% /K |
| Coefficient of Power | -0.47% /K |

Tested Operating Conditions

| | |
|----------------------------|---------------|
| Temperature Cycling Range | -40°C to 85°C |
| Humidity Freeze, Damp Heat | 85% RH |

Product Guarantee

| | |
|----------------------|---|
| Product Warranty | 12 Years |
| Performance Warranty | First 10 Years up to 90%, next 15 years up to 80% |

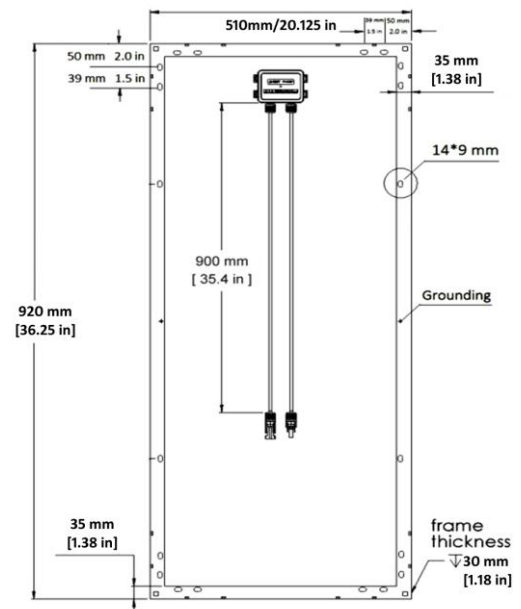
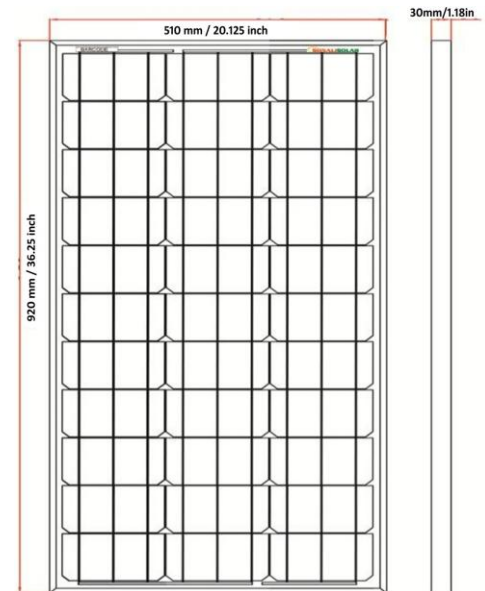

Linear Performance Warranty

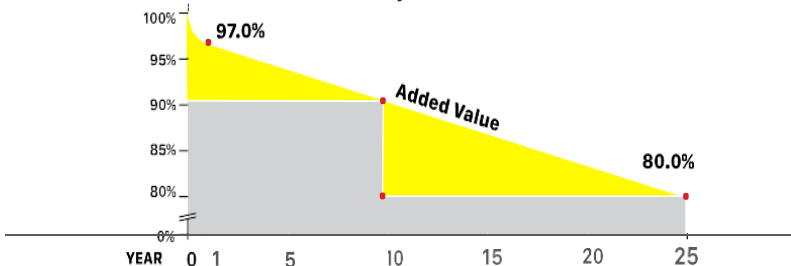

IV Curve Measurement Performance

