

# Installation Manual

LTP-LCR HW Manual v1.0

For models:

LTP-LCR/82HW

LTP-LCR/124HW



**Table of Contents**

Introduction ..... 1

Customer Support ..... 1

**Tools Required** ..... 2

**Components List** The following parts are used on the LTP-LCR/82HW LTP-LCR/124HW mount models: ..... 2

**Pre Assembly for Models LTP-LCR/82HW LTP-LCR/124HW** ..... 3

**Step 1: Connecting Panel Support Channels (LTP-LCR/124HW only)** ..... 3

**Step 2: Connecting Cross Rails LTP-LCR/82HW LTP-LCR/124HW** ..... 3

**Step 3: Connecting Knee Brace Channels LTP-LCR/82HW LTP-LCR/124HW** ..... 3

**Final Assembly**..... 3

**Step 5: Attach Pole Clamp Assembly to Pole** ..... 3

**Step 6: Attach Tilt Plate Mounting Channel** ..... 4

**Step 7: Attach Tilt plates** ..... 4

**Step 8: Attach Cross Rails to Tilt Plates.** ..... 4

**Step 11: Adjust Tilt Angle** ..... 5

**Detailed Diagrams for Assembly** ..... 6

Foundation Hole Guidelines..... 14

Installer Responsibility..... 16

Warranty Information ..... 16

**Introduction**

The Top of Pole Mount is an extremely sturdy, universal pole mounting solution for small area solar photovoltaic (PV) needs. With its user adjustable angle settings (0° to 60° in 10° increments), the Top of Pole Mount can support installations in a wide range of locations.

**Customer Support**

Tamarack Solar makes every effort to ensure your mounting kit is easy to install. If you need assistance at any point in your installation or have suggestions on how we can improve your experience, call customer support at **1-800-819-7236** or email us

**Tools Required**

Tools that support the following size hex heads: Torque values are “dry”, add 15% if using anti-seize lubricant on stainless hardware (Recommended). Deep sockets for 5/16” and 1/2”, long combination wrench for 5/16.

1. 1/2” = 480\40 In\Ft Lbs
2. 3/8” = 240\20 In\Ft Lbs
3. 5/16” = 144\12 In\Ft Lbs
4. 1/4” = 84\7 In\Ft Lbs

**Components List** The following parts are used on the LTP-LCR/82 HW LTP-LCR/124HW mount models:

***Galvanized coated sheet steel components will show rust on cut edges and is normal and will not affect the structure and function of the mount.***

PART NUMBER	DESCRIPTION	82HW	124HW
		QTY.	QTY.
51-07BC-TLT REV A	Channel, Tilt Plate Mounting	2	2
51-07TP-LR2 REV C	Tilt Plate L\ R	2	2
51-07CR-066 REV C	Cross Rail, 66 Inch	6	6
51-07SP-060 REV A	Cross Rail Connector	3	3
51-07TC-068 REV A	Panel Support TP <b>68 inch</b>	0	4
51-07TC-056 REV A	Panel Support TP <b>56 inch</b>	0	4
51-04TC-082 REV B	Panel Support TP <b>82 inch</b>	4	0
51-07CN-030 REV C	Connector, 30"	0	4
51-07KC-066 REV A	Knee brace Channel, 66 inch	2	2
51-07SP-015 REV A	Knee brace Channel Connector	1	1
51-0534-HWI rev A	Inner Brace Channel	2	0
51-0534-HWO rev A	Outer Brace Channel	2	0
51-0539-HWI rev A	Inner Brace Channel	0	2
51-0539-HWO rev A	Outer Brace Channel	0	2
51-06HW-015 rev A	Inner Swivel Bracket	2	2
51-06HW-020 rev A	Outer Swivel Bracket	4	4
51-07KB-58HW rev A	Attaching Bracket	2	2
51-07KB-59HW rev A	Clamp, 6" Knee Brace	1	1
23-0675-GLV	Bolt, U 1/2-13 6" Pipe HDG	1	1

PART NUMBER	DESCRIPTION	82HW	124HW
		QTY.	QTY.
23-5013-125	Bolt, 1/2-13x1.25" HDG	10	10
25-5002-GLV	Washer, Flat 1/2" HDG	22	22
25-5001-GLV	Washer, Lock 1/2" HDG	12	12
24-5013-GLV	Nut, Hex 1/2-13 Fin HDG	12	12
23-3716-100	Bolt, 3/8-16 x 1.0 Hex SST.	60	60
25-3702-000	Washer, Flat 3/8" SST.	72	72
25-3701-000	Washer, lock 3/8" SST.	12	12
24-3716-440	Nut, 3/8-16 Hex SST.	12	12
25-2501-016	Nut, Flange Serrated 3/8-16 SST.	48	48
51-0756-890	Rod, threaded, SST 5/16-18 x 8.9" long	4	4
23-3118-350	BOLT Hex 5/16-18 x 3.5" SST	6	6
23-3118-850	Bolt, 5/16-18 x 1.0 Hex CS SS	1	1
23-3118-875	Bolt, 5/16-18 x 7/8 Hex CS SS	24	40
25-3102-000	Washer, flat 5/16" SS	31	47
25-2501-015	Nut, flange 5/16 SST	47	63
23-2520-050	Bolt, Hex 1/4-20 x .75 SST	36	44
25-2502-000	Washer, flat 1/4 SS	68	68
25-2501-000	Washer, lock 1/4"	32	24
24-2520-440	Nut, 1/4-20 fin hex SS	32	24
25-2501-014	Nut, Flange Serrated 1/4-20 SST	4	20

## Pre Assembly for Models LTP-LCR/82HW LTP-LCR/124HW

### Step 1: Connecting Panel Support Channels (LTP-LCR/124HW only)

- A. Lay (1) 56" and (1) 68" panel support channel end to end with a connector in the middle.  
**NOTE: You will need 2 sets, (2 lefts and 2 rights), keep 56" supports on the same end with open sides facing each other (Detail A).**
- B. Using a connector, bolt the panel support channels together. Tighten the 5/16-18 x 7/8" hardware (hex bolt, flat washer, and flange nut) to 144 in-lbs (dry). Repeat with the remaining set of channel rails and set aside.

### Step 2: Connecting Cross Rails LTP-LCR/82HW LTP-LCR/124HW

- A. Lay two cross rails end to end with a connector in the middle. **(Detail B) (Make 3 sets)**
- B. Using a connector, bolt the cross rails together. Tighten the 3/8-16 x 1" hardware (hex bolt, flat washer, and flange nut) to 20 ft-lbs (dry). Repeat with the remaining set of cross rails and set aside.

### Step 3: Connecting Knee Brace Channels LTP-LCR/82HW LTP-LCR/124HW

- A. Lay two knee brace channels end to end with a connector in the middle. **(Detail C) (Make 1 set)**
- B. Using a connector, bolt the knee brace channels together. Tighten the 5/16-18 x 7/8" hardware (hex bolt, flat washer, and flange nut) to 144 in-lbs (dry).

### Step 4: Connecting Panels to Panel Supports

**(LTP-LCR/124HW) 3 panels per tier, connect middle panel only, (Detail D)**  
**(LTP-LCR/82HW) 2 panels per tier, connect both panels**

- A. Lay panel(s) on a flat surface, frame side up.
- B. Lay panel supports across the panel(s) with obround slots face down, and the open sides facing towards the center of the panel, aligning the mounting holes of the panel with the obround slots on the panel supports, placing the panel in the center (3 panel tier shown **Detail D**) or equally spaced (2 panel tier) **Detail DD**. Install with 1/4 x 3/4 bolts, flats, locks and nuts, tighten only enough to hold firmly, **do not torque at this time**.

## Final Assembly

### Step 5: Attach Pole Clamp Assembly to Pole

- A. Slide the pre-assembled pole clamp over the pole, the assembly should rest on the notches on the top edge of the pole. **(Detail E)**.
- B. Loosen the four 1/4" bolts slightly to allow the clamp halves to tighten up on the pole.
- C. Orientate brace to face south.
- D. Tighten the 8 outside 5/16 flange nuts on the threaded rods evenly, making sure that each nut is tightened the same amount of turns so the distance between the clamp halves is the same on each side of the pole, until the torque setting is reached. 12 Ft-lbs (dry).
- E. Finger tighten the 8 inside 5/16 flange nuts up to the flanges of the clamp halves.
- F. Using a long 5/16 box wrench, tighten 5/16 flange nuts, alternating turns from side to side, pulling the flanges together. (Close or touching, not flattened out).
- G. Install 5/16 x 7/8 bolt, flat, and flange nuts in the 4 holes of the clamp halves flange ends. Tighten 5/16 bolts, alternating turns from side to side, pulling the flanges together. (close or touching, not flattened out) **(Detail F)**.

- H. **Check the torque of the 8 outside flange nuts**, re torque as needed.
- I. Torque the four 1/4" bolts on top to 84 in-lbs. **(previously loosened slightly)**
- J. **(Optional)** caulk the seams on top of pipe clamp to seal preventing rain water entering the pipe.

### Step 6: Attach Tilt Plate Mounting Channel

- A. Place tilt plate mounting channels on the sides of the pole clamp assembly **(Detail G)**.  
**See helpful tip image**
- B. Install 1/4" bolt, flat and flange nuts 6 places on both sides, tighten to 84 in-lbs. Note: placing the flange nut in the "closed" side of the wrench to align with the bolt through the cutout will make it easier to start.  
**(Detail H)** Dropped nuts cannot be retrieved very easily.

### Step 7: Attach Tilt plates

- A. Attach tilt plates, flanges facing to the outside using 1/2-13 x 1.25 bolts, flats, locks and nuts; position the tilt plates with the top parallel to the ground (0°). Do not torque at this time, tighten only enough to hold firmly for next assembly steps. **(Detail I)**.

### Step 8: Attach Cross Rails to Tilt Plates.

- A. Attach cross rails to the tilt plates, open sides facing to the inside, (CENTERED) using 1/2-13 x 1.25 bolts, flats, locks and nuts. Torque to 40 ft-lbs. **(Detail J)**

### Step 9: Attach Panel Support Sub Assembly to Cross Rails

- A. Lean the 124" or the 82" sub assembly against the cross rail **(Detail K)**, to left side, lift the end up and slide sub assembly onto both cross rails and place the seam where the 56" and 68" panel supports meet, centered between the cross rails, for the **(LTP-LCR/124HW)** **(Note: 56" section to be on the north side of the cross rails.)** or 22 7/8" from the end of the 82" panel support to the north side cross rail face **(Detail KK)** drop four 3/8 x 1" bolts and flats to align panel supports **(Detail L)**, check the spacing of panel inside end to the center of the cross rails **(Detail M)**, move in or out for 1/2 of the desired spacing between panels (east to west), add the bottom flat, lock washer and nut. Torque the 3/8 x 1" bolts to 20 ft-lbs (4) Places.
- B. Repeat for the right side.
- C. **(LTP-LCR/124HW)** Lift next panel up onto the panel supports on the north side; align mounting holes so the inside panel edges are approximately 1" apart. Loosely install with 1/4 x 3/4 bolts, flat, lock and nuts. Repeat with the panels on the south side.
- D. Final adjust spacing of all the panels to be even and parallel, and Torque to 84 in-lbs.

### Step 10: Install Knee and Cross Brace Channels LTP-LCR/82HW LTP-LCR/124HW

- A. Install knee brace channel assembly (open side facing the pole), across the north side in the last hole in from the end of the panel supports with the 5/16-18 x 7/8" hardware (hex bolt, flat washer, and flange nut) torque to 144 in-lbs (dry). **(DETAIL Q)**. The ends of the knee brace channels will be the same distance in as the cross rails are to the panel supports.
- B. Repeat across the south side **using the third set of cross rails** previously pre-assembled, **(DETAIL QQ)** Note: location is determined by the final desired angle setting for the array, see **(DETAIL N)**.

### Step 11: Adjust Tilt Angle

- A. Remove the lower two 1/2-13 x 1.25" bolts from the tilt plates and tilt the array to desired angle, the array tilts in 10° increments from 0° to 60°. Re install 1/2-13 bolts and torque all six 1/2-13 bolts to 40 ft-lbs

### Step 12: Install Lower Vee Brace LTP-LCR/82HW LTP-LCR/124HW

- A. Pre assemble the lower brace clamp body to the angle brackets with 1/4" x 3/4" Bolts, Flats and flange nuts, torque to 84 in-lb. **(Detail O) set aside the 5/16-18 x 1.0 bolt, flat and flange nut attached to one of the angle brackets.**
- B. Attach the lower knee brace clamp loosely to the pole with the 1/2-13 x 6" U-bolt flat, lock and nut. **(Detail O)** See **(DETAIL N)** for location position.
- C. Loosely attach the outer swivel brackets to the lower knee brace clamp with the (previously set aside) 5/16-18 x1.0 bolt, flat washer and flange nut. **Note: the 2 outer holes must face away from the pole. (Detail P).**
- D. Attach the outer swivel brackets to the cross rail sub assembly at both ends with 5/16-18 x 7/8 bolt, flat washer and flange nut. **Flange nut to be inside of the knee brace channel.** Tighten to 144 in-lbs (dry) **(Detail QQ)**.
- E. Loosely attach the inner swivel brackets to the outer swivel brackets just installed on the cross rail sub assembly. **(Detail R).**
- F. Loosely attach the 34.5" (LTP-LCR/82HW) or 39.5" (LTP-LCR/124HW) outer brace channels to the outer swivel brackets at the pole, open side facing in, with 5/16-18 x3.5 bolt, flat washer and flange nut. **(Detail S).**
- G. Loosely attach the 34.5" (LTP-LCR/82HW) or 39.5" (LTP-LCR/124HW) Inner brace channels to the inner swivel brackets on the cross rail sub assembly, open side facing in, with 5/16-18 x3.5 bolt, flat washer and flange nut. **(Detail T).**
- H. Adjust the lower knee brace clamp up or down to the approximate location based on the final angle **(DETAIL XXX)** so the inner and outer channel holes align with each other and install the 5/16-18 x 7/8 bolt, flat washer and flange nut at the hole nearest to each end of the inner and outer channels. **Note: there must be a minimum 6" overlap of the inner and outer channels.** Tighten all 5/16 hardware to 144 in-lbs (dry). **(Detail U).**

Detailed Diagrams for Assembly

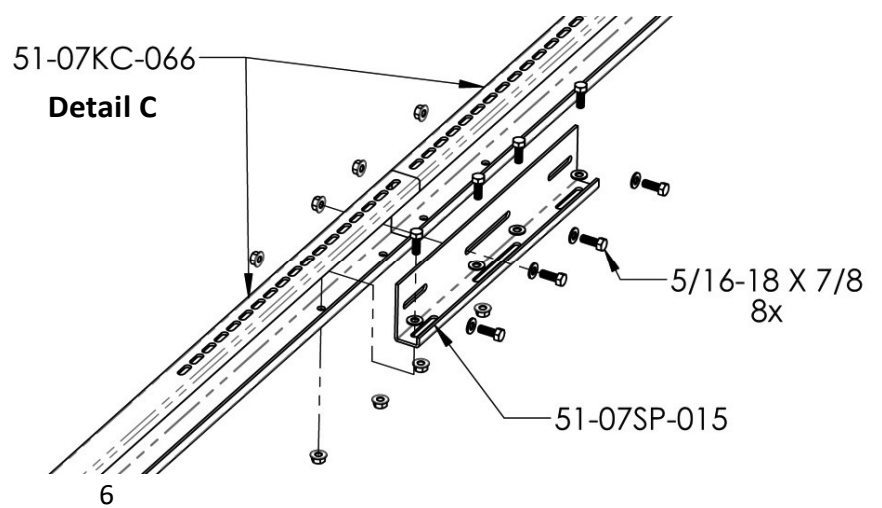
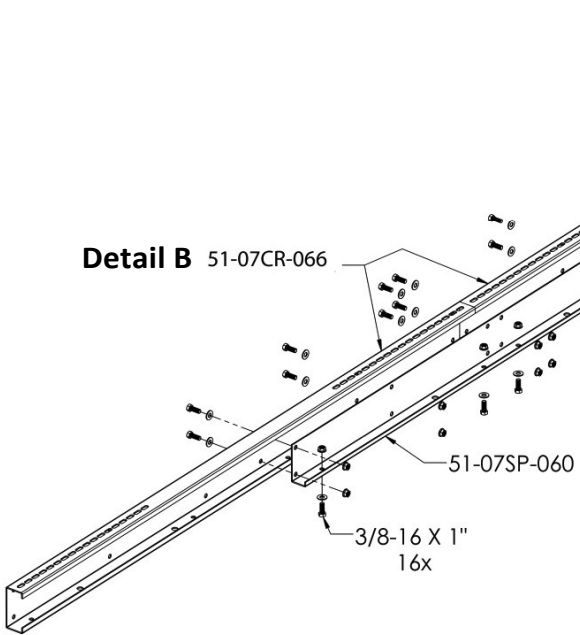
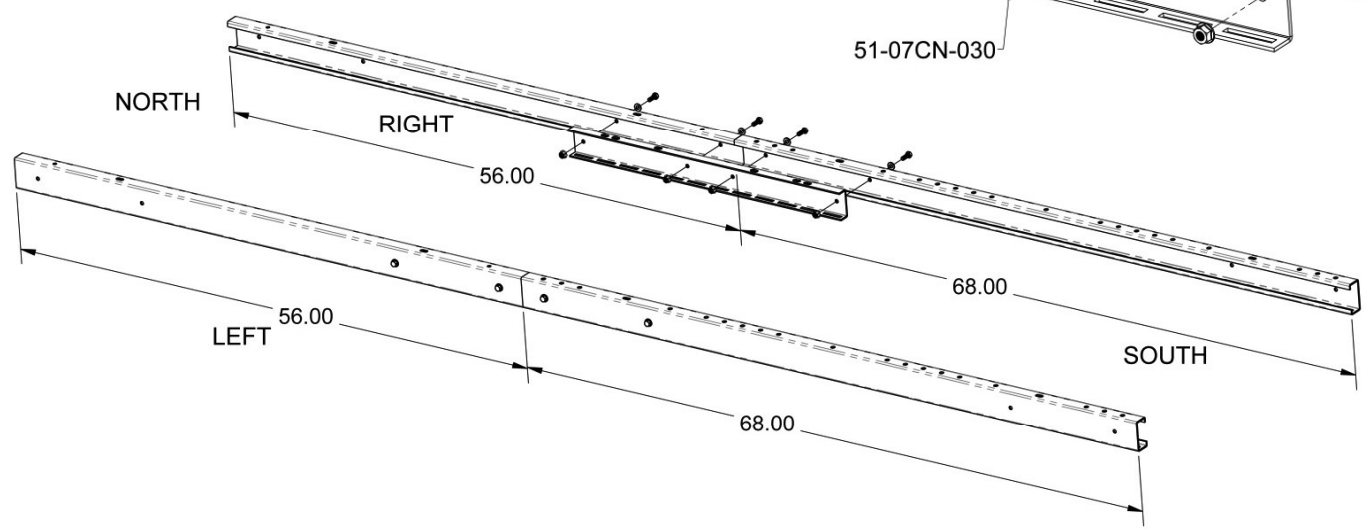
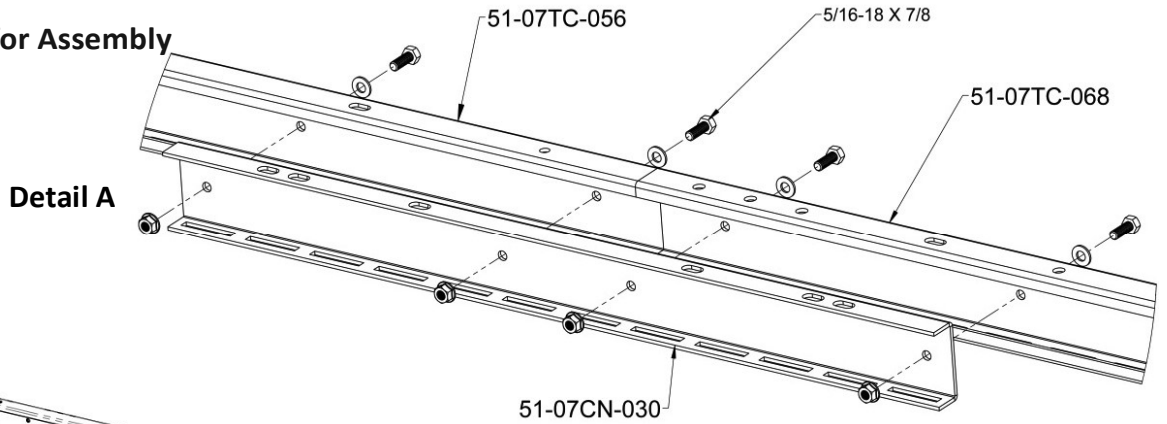

Detail D

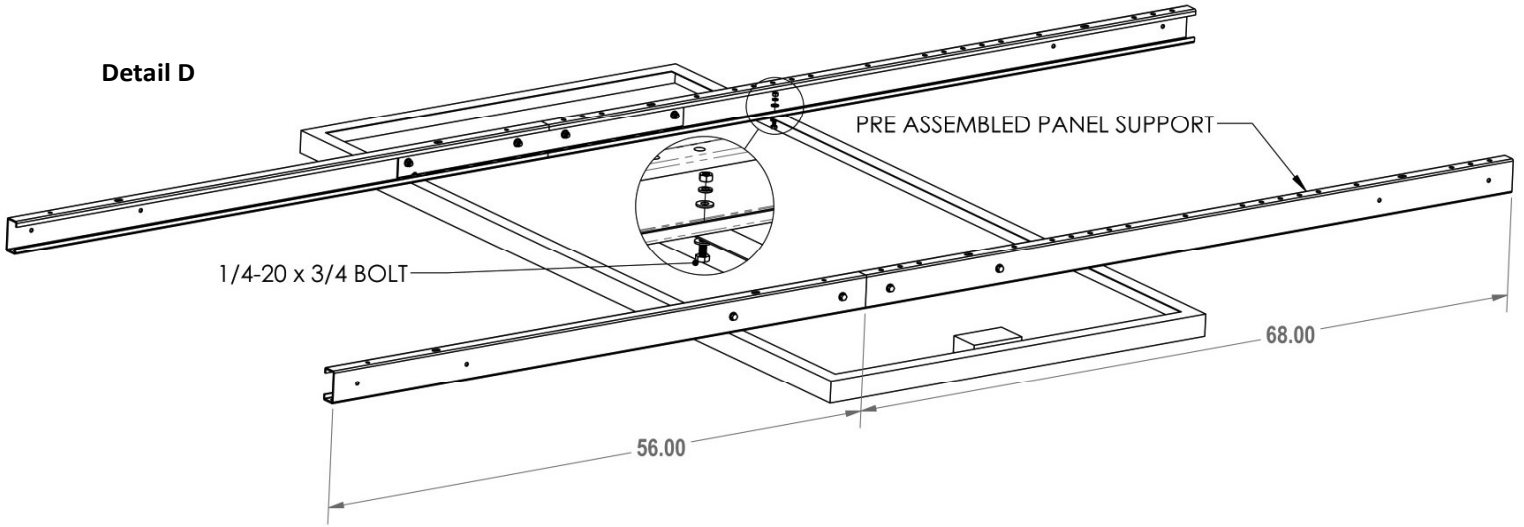

Detail DD

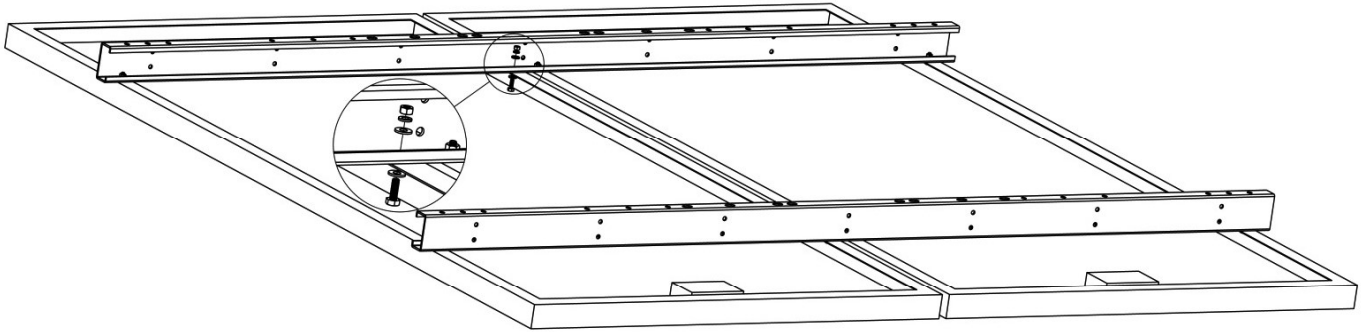

Detail E

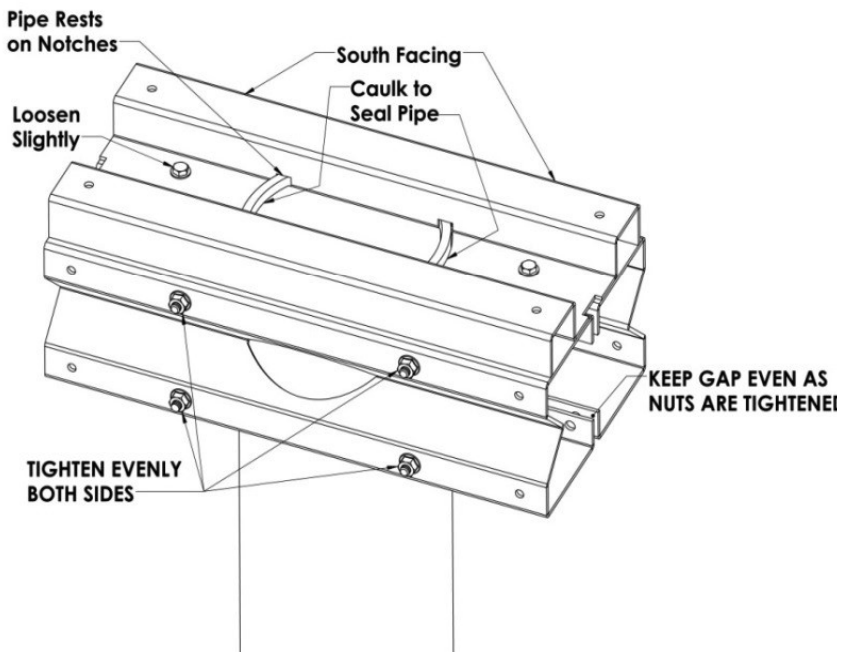

Detail F

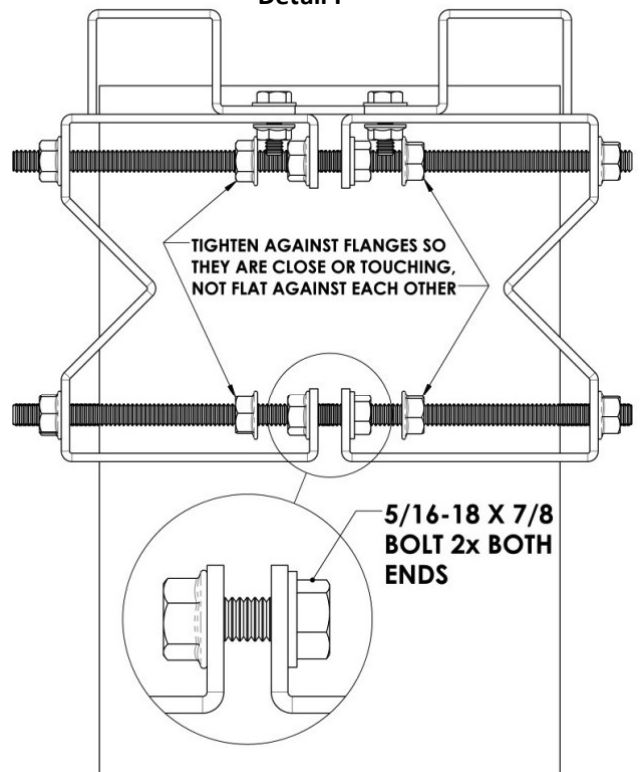

Detail G

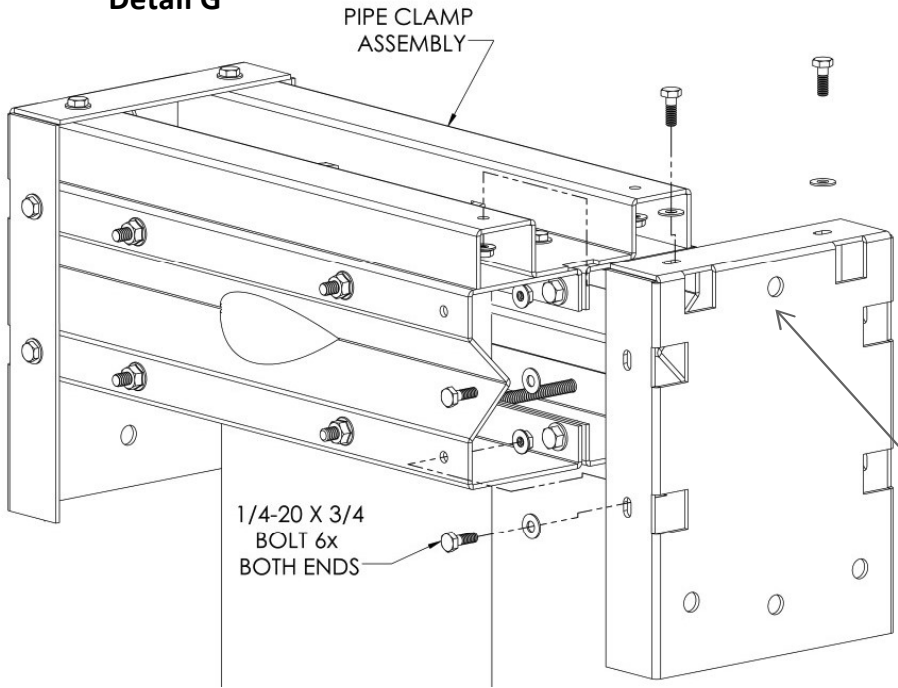

Detail H



Helpful tip: pre install - 1/2" bolt for ease of assembly in Detail I.

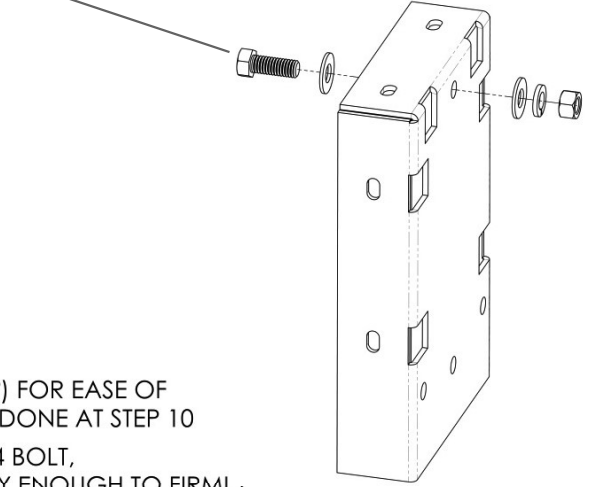

Detail I

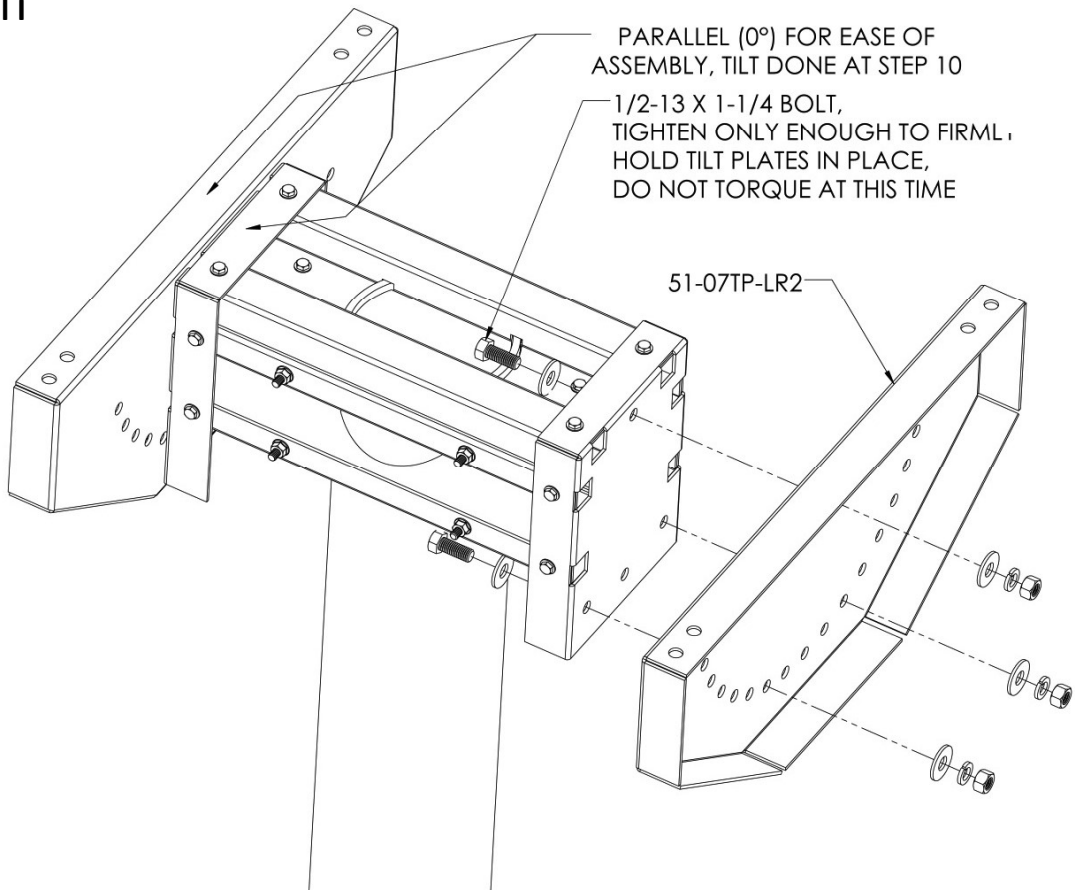

Detail J

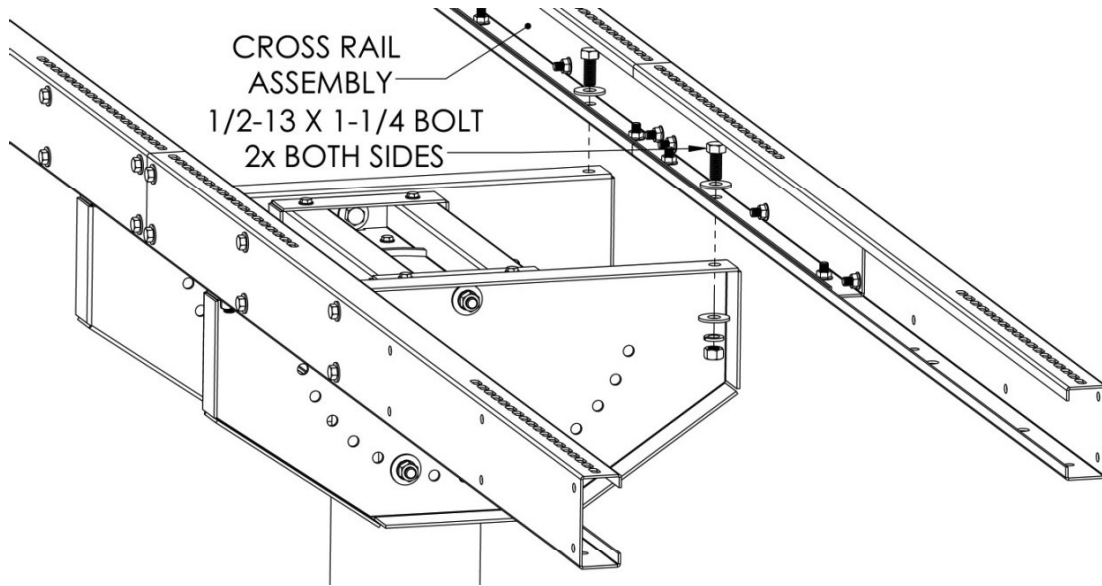

DETAIL K



DETAIL L

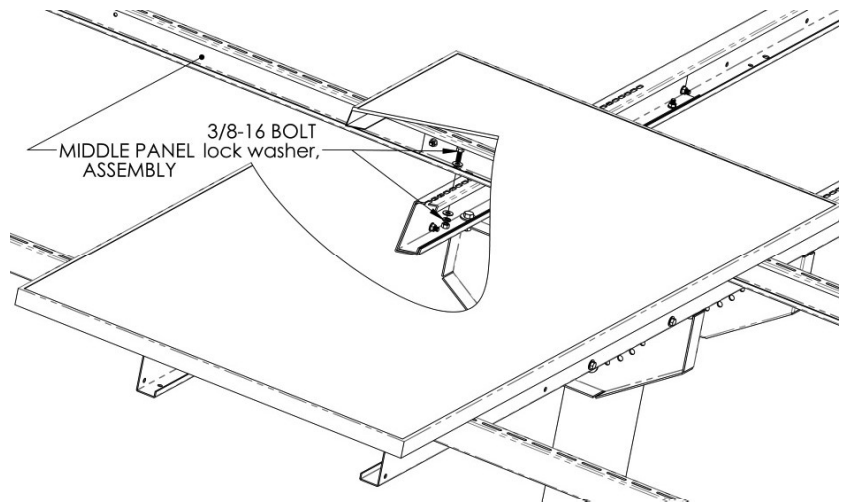

DETAIL KK

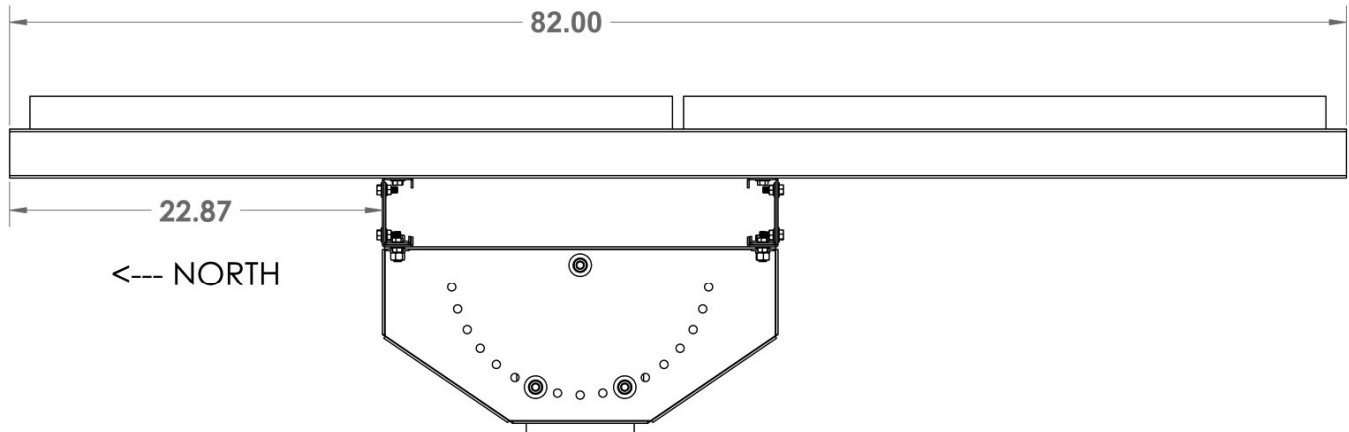

DETAIL M

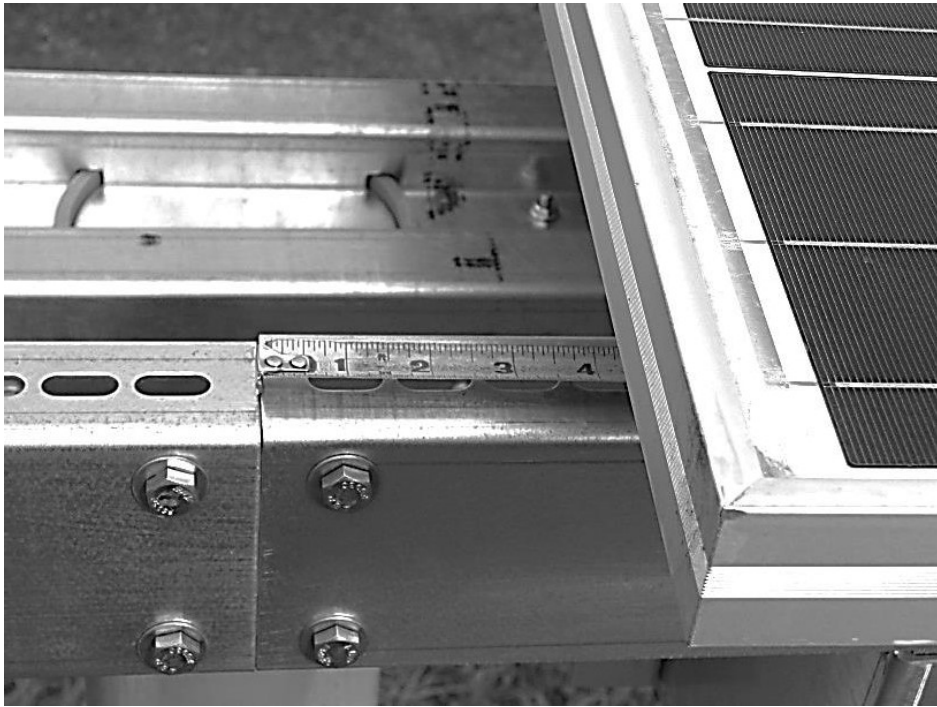

DETAIL N

(LTP-LCR/124HW shown)

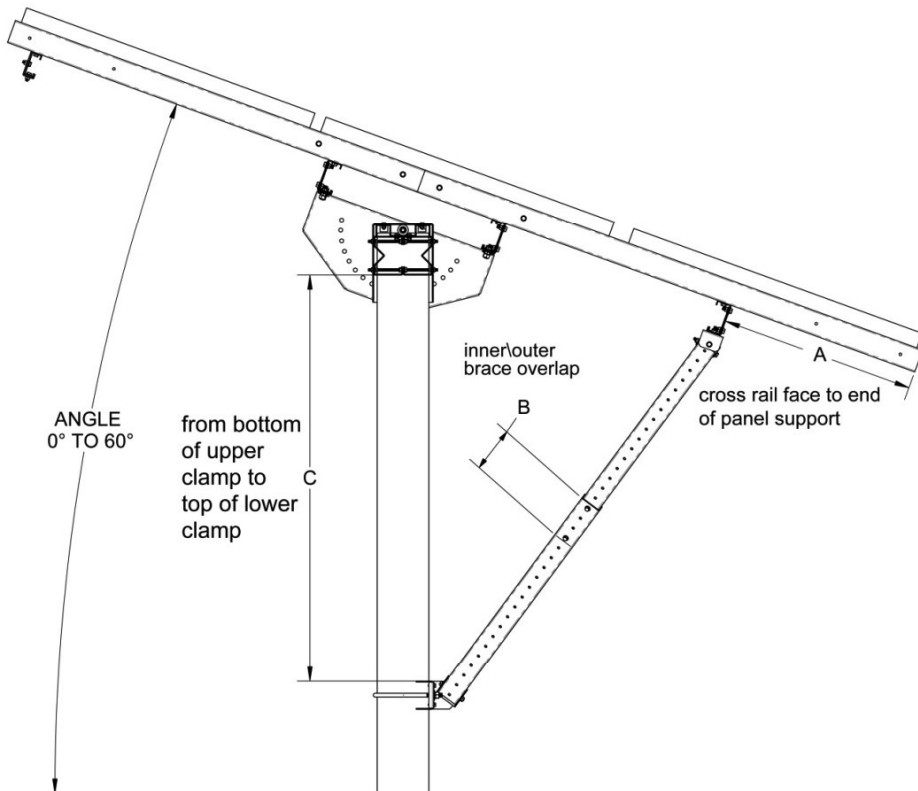

Location Chart LTP-LCR/124HW			
ANGLE	A	B	C
0°	33.09	7.50	41.60
10°	25.10	7.50	43.85
20°	25.10	7.50	52.39
30°	23.10	13.50	51.00
40°	23.10	19.50	49.75
50°	15.10	23.50	51.96
60°	15.10	29.50	47.05

Location Chart LTP-LCR/82HW			
ANGLE	A	B	C
0°	19.06	6.50	31.52
10°	19.06	6.50	36.45
20°	15.06	6.50	40.94
30°	5.06	6.50	46.09
40°	3.06	8.50	51.65
50°	1.06	16.50	43.58
60°	1.06	20.50	42.10

DETAIL O

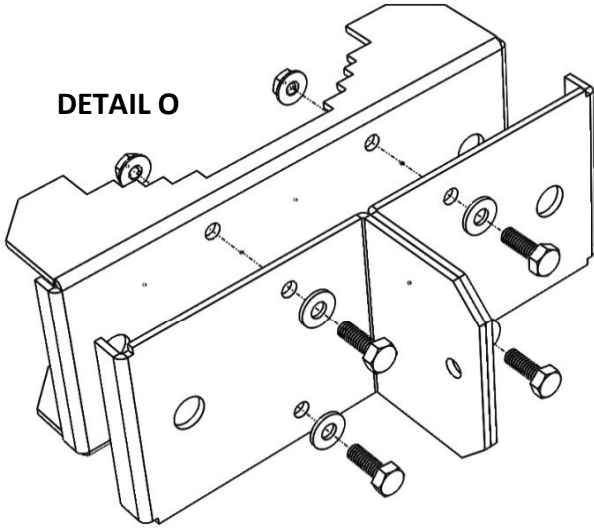

DETAIL P

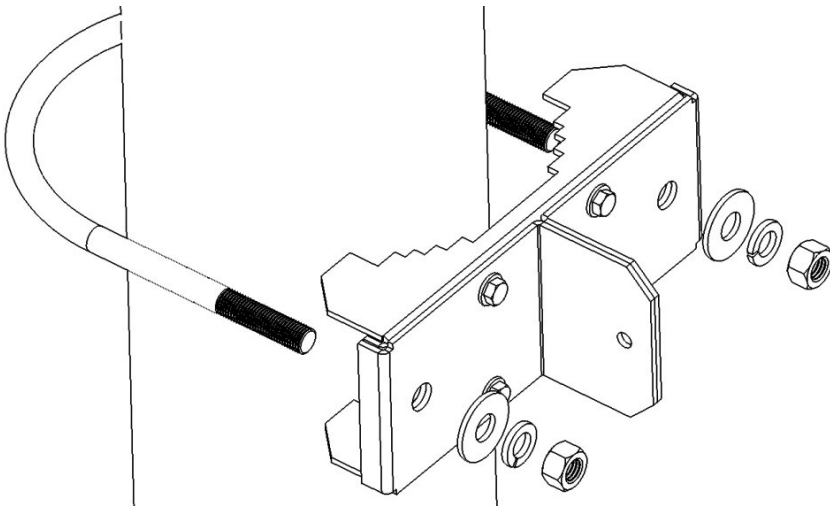
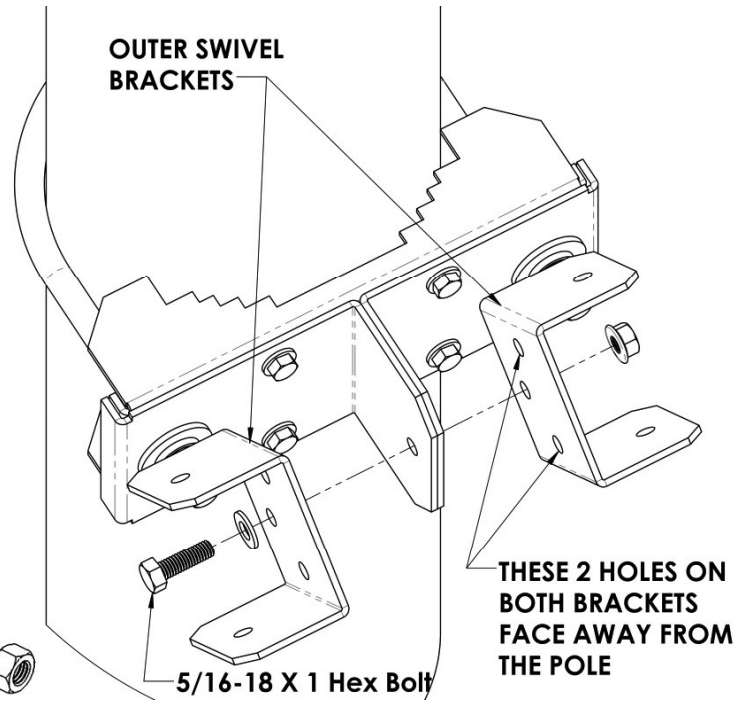

DETAIL QQ

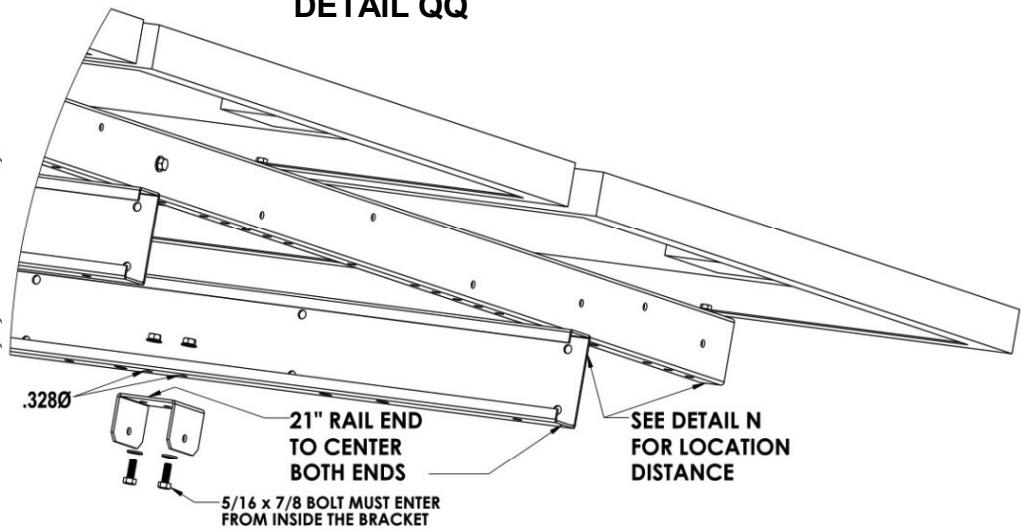

DETAIL Q

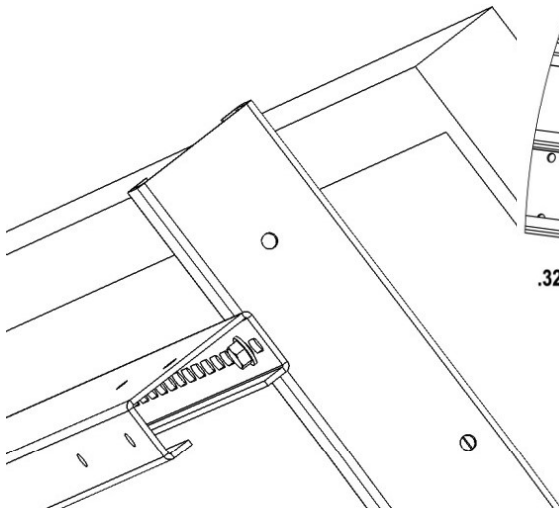

DETAIL R

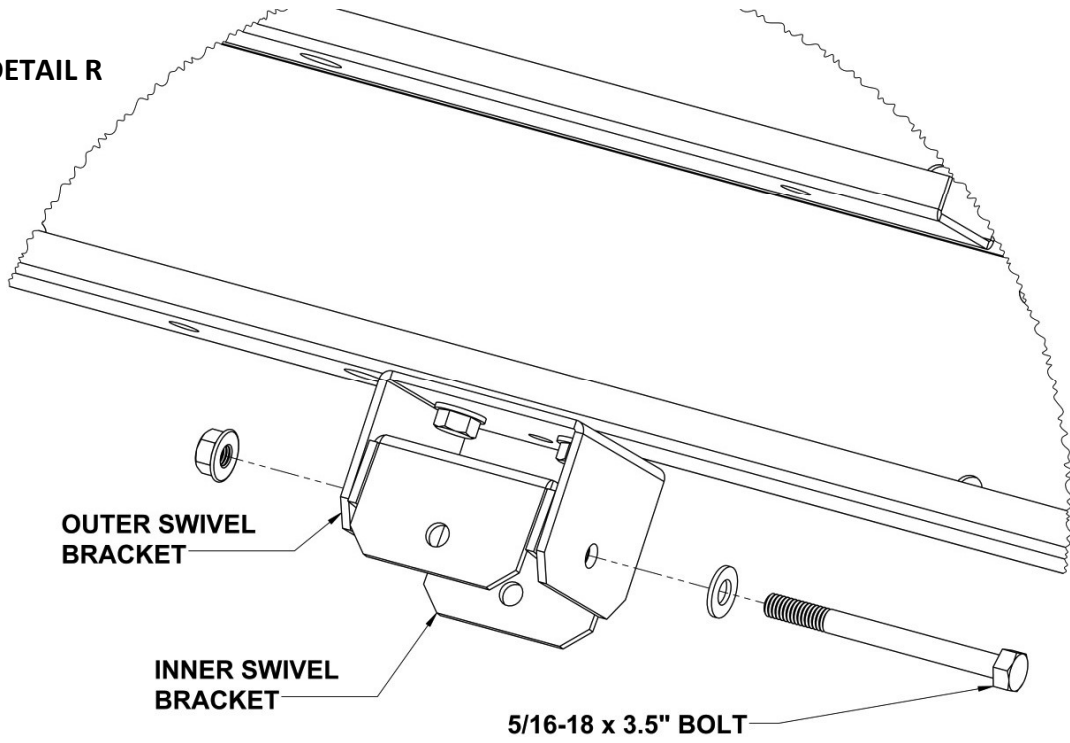

DETAIL S

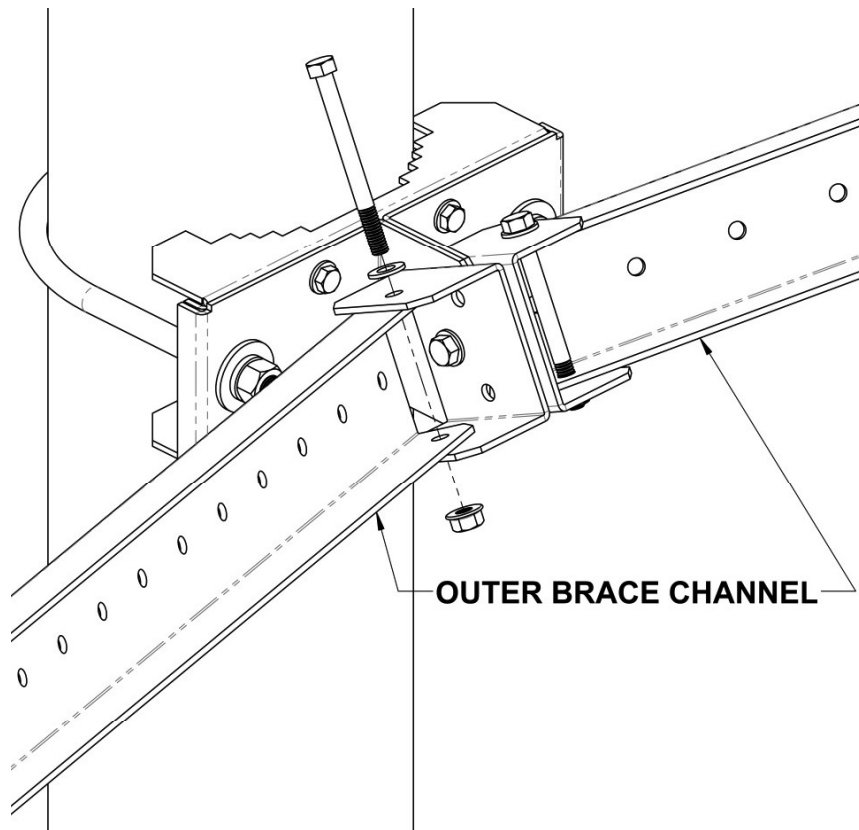

**DETAIL T**

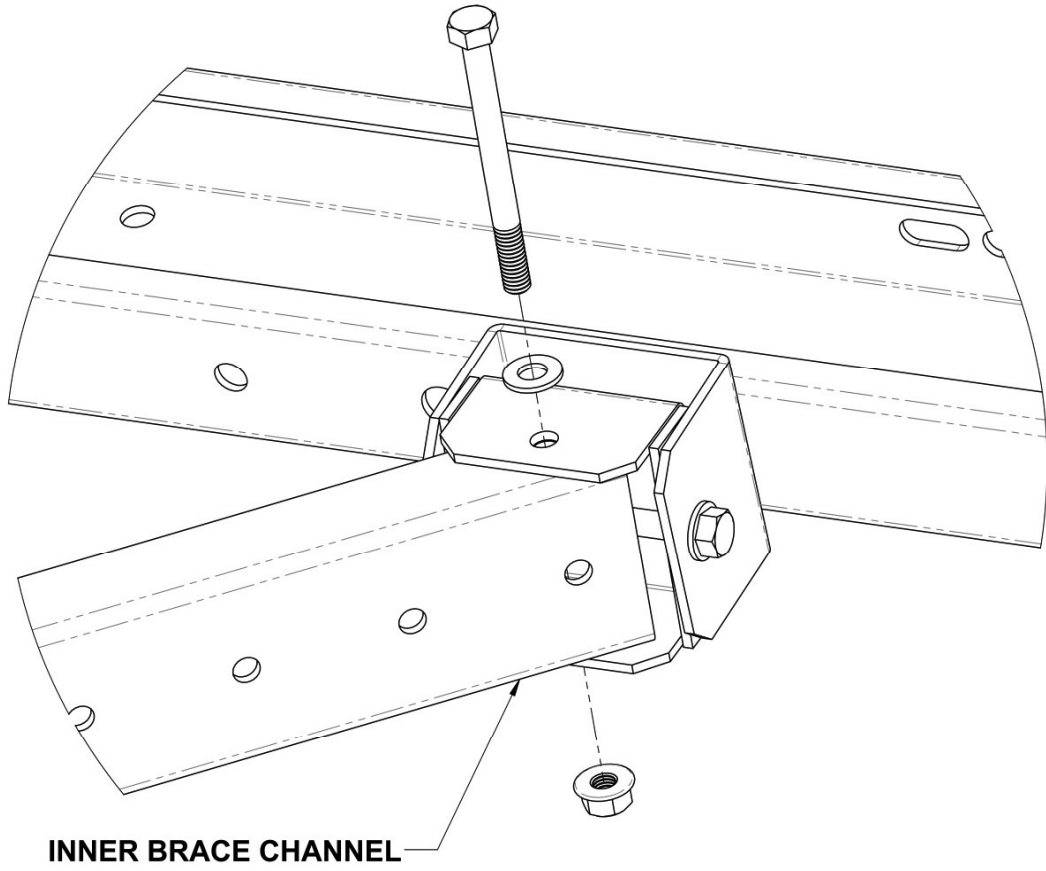

**DETAIL U**

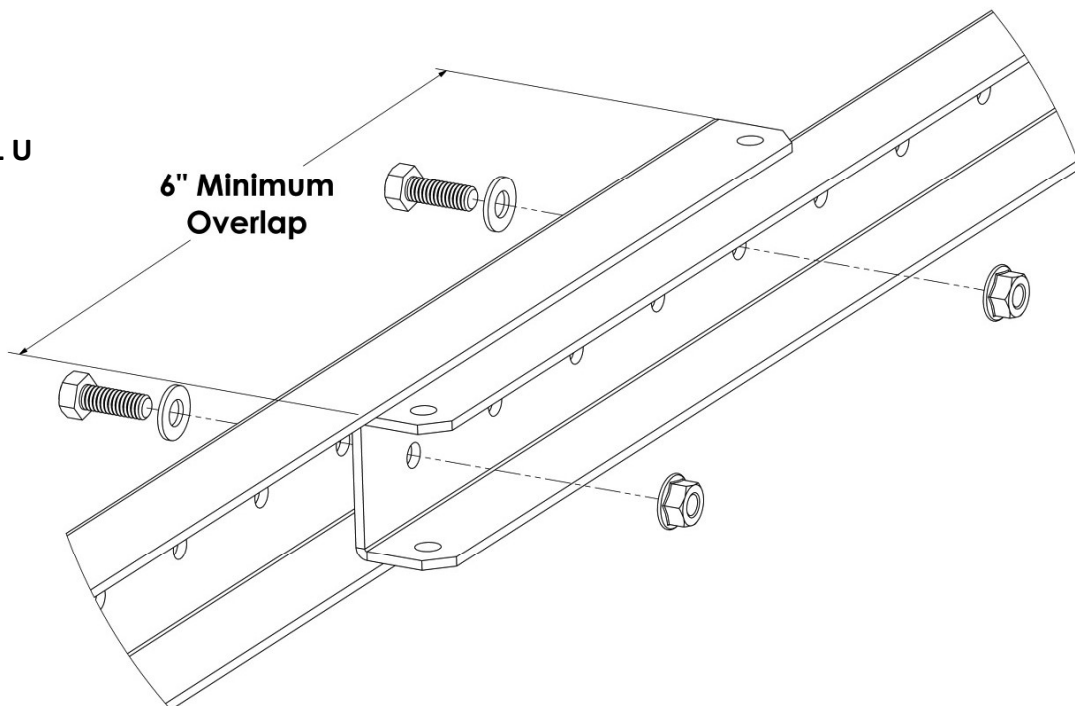

### Foundation Hole Guidelines

The suggestions below are **recommendations only**. It is the installer's responsibility to validate foundation parameters prior to installation, as local geotechnical report may be required to assess ground conditions. We recommend consulting with a local engineer familiar with local regulations and build site requirements, including soil conditions, terrain and load criteria (wind, snow, seismic). All of these parameters may impact foundation requirements. Lines **highlighted**, requires the High Load Kit.

4 Module 60 cell	Footing depth\feet		Footing depth\feet		6" Pipe sch		6 Module 60 cell	Footing depth\feet		Footing depth\feet		6" Pipe sch
Soil Type	Class 5		Class 4				Soil Type	Class 5		Class 4		
Hole diameter	18"	30"	18"	30"			Hole diameter	18"	30"	18"	30"	
0°	5.00	4.25	4.25	3.75	40		0°	4.50	3.75	4.00	3.25	40
10°	5.75	4.25	5.75	3.75	40		10°	5.50	4.50	4.75	4.00	40
20°	6.75	5.75	5.75	4.75	40		20°	6.75	5.50	5.75	4.75	40
20° High Load	7.00	6.00	6.00	5.00	40		20° High Load	7.00	5.75	6.00	5.00	40
30°	8.00	6.50	6.75	5.50	40		30°	8.25	6.75	7.00	5.75	40
30° High Load	8.50	7.00	7.25	6.00	40		30° High Load	8.75	7.25	7.50	6.25	40
40°	8.50	6.75	7.25	5.75	40		40°	9.00	7.25	7.75	6.25	40
40° High Load	11.00	9.00	9.50	7.50	40		40° High Load	9.75	8.00	8.50	7.00	40
50°	9.25	7.50	7.75	6.25	40		50°	N/A	N/A	N/A	N/A	N/A
50° High Load	11.25	9.50	10.00	8.00	80		50° High Load	11.00	9.00	9.25	7.50	80
60°	9.75	8.00	8.50	7.00	40		60°	N/A	N/A	N/A	N/A	N/A
60° High Load	12.50	10.00	10.50	8.50	80		60° High Load	11.50	9.50	9.75	8.00	80

4 Module 72 cell	Footing depth\feet		Footing depth\feet		6" Pipe sch		6 Module 72 cell	Footing depth\feet		Footing depth\feet		6" Pipe sch
Soil Type	Class 5		Class 4				Soil Type	Class 5		Class 4		
Hole diameter	18"	30"	18"	30"			Hole diameter	18"	30"	18"	30"	
0°	5.25	4.25	4.50	3.75	40		0°	4.50	3.75	4.25	3.25	40
10°	6.25	5.00	5.50	4.50	40		10°	6.25	5.00	5.25	4.25	40
20°	7.00	5.75	6.00	4.75	40		20°	6.75	5.50	5.75	4.75	40
20° High Load	7.50	6.25	6.50	5.25	40		20° High Load	7.50	6.00	6.25	5.25	40
30°	7.50	6.25	6.50	5.25	40		30°	8.25	6.50	7.00	5.75	40
30° High Load	8.25	6.75	7.25	5.50	40		30° High Load	9.25	7.75	8.00	6.75	40
40°	8.50	7.00	7.25	5.75	40		40°	N/A	N/A	N/A	N/A	N/A
40° High Load	11.50	9.50	10.00	8.00	40		40° High Load	10.00	8.25	8.75	7.25	40
50°	N/A	N/A	N/A	N/A	N/A		50°	N/A	N/A	N/A	N/A	N/A
50° High Load	12.50	10.00	10.50	8.50	80		50° High Load	11.25	9.00	9.50	7.75	80
60°	N/A	N/A	N/A	N/A	N/A		60°	N/A	N/A	N/A	N/A	N/A
60° High Load	12.25	10.00	10.50	8.50	80		60° High Load	11.75	9.50	10.00	8.00	80

**Installation Recommendations: Concrete to be min 3,500 PSI**

1. Auger hole to minimum depth shown in foundation guidelines, + 6" for (#2).  
Drilled holes to be filled with concrete shall be cleaned to remove all loose cuttings.
2. Stumps or other decomposable material exceeding 3 inches in the least dimension located within the drilled diameter of the foundation shall be removed entirely prior to placing concrete.
3. The bottom 6" of hole should be filled with crushed rock or a blocking; this will prevent the pipe(s) from touching the base of the hole, insuring complete encapsulation of the pipe when concrete is poured, as well as allowing for water drainage. (see option 1)
4. The pipe(s) should be installed vertically no matter the slope of the install site and centered in the hole.
5. Make arrangements to prevent the pipe(s) from twisting or moving prior to and during pouring of the concrete.
6. The pipe(s) should be braced to remain plumb and in position until concrete has cured at least 24hrs.
7. The solar system shall not be attached to the support pipe until the concrete has reached 3,500 psi.

**The Steel Post shall be embedded into the concrete pier using one of the following options:**

- A. **Option 1:** To within 12" of the bottom of the concrete pier.
- B. **Option 2:** The steel post embedment shall be a minimum of 36" into the concrete pier with (2) #5 bars extending vertically to within 12" of the bottom of the pier, one on each side of the steel post. The rebar shall lap with the steel post a minimum of 30". A bolt (5/16" minimum) shall be placed through the steel post at approximately 6" (+/- 2") from the bottom of the post with a hand tightened nut to provide uplift resistance in direct bearing with the concrete

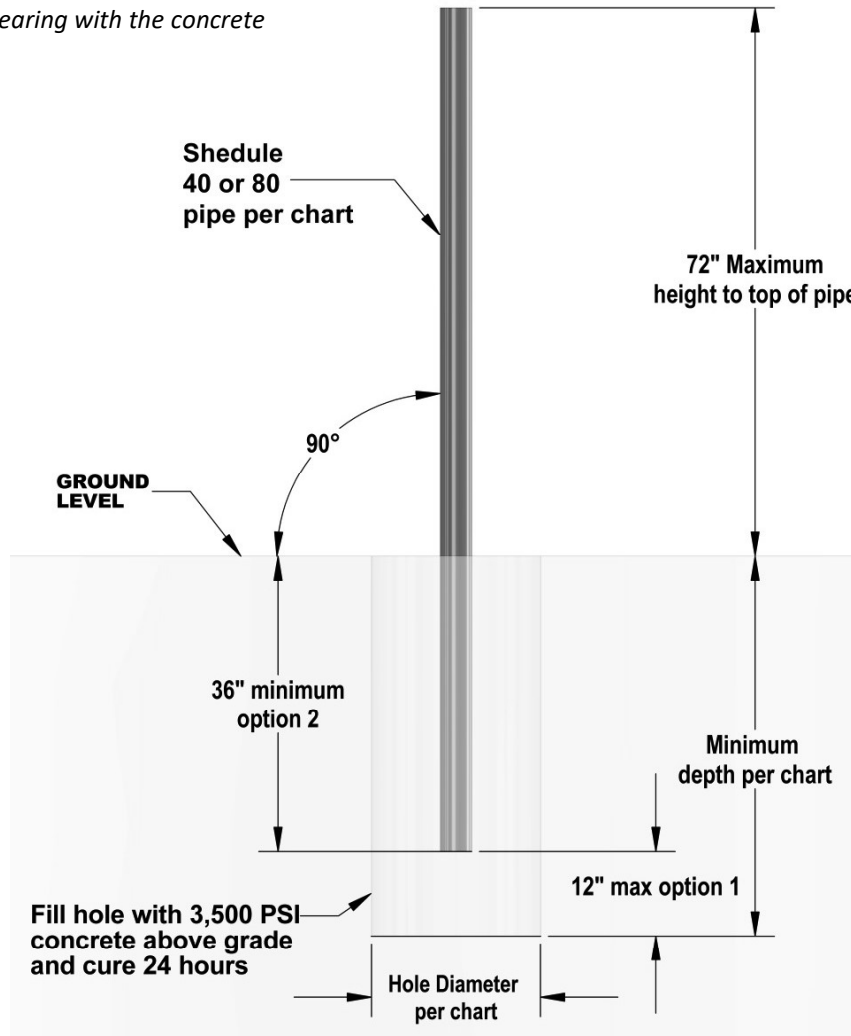

## Installer Responsibility

The installer is solely responsible for:

Complying with all applicable local or national building codes, including any that may supersede this manual;

Ensuring that Tamarack Solar and other products are appropriate for the particular installation and the installation environment;

Using only Tamarack Solar parts and installer-supplied parts as specified by Tamarack Solar. Substitution parts may void the warranty;

Ensuring safe installation of all electrical aspects of the PV array; and

Ensuring correct and appropriate design parameters are used in determining the design loading used for the specific installation. Parameters, such as snow loading, wind speed, exposure and topographic factor should be confirmed with the local building official or a licensed professional engineer.

## Warranty Information

Tamarack Solar warrants each Mounting Structure to be free from defects in materials and workmanship for ten (10) years from the date of first purchase (“Warranty Period”), when installed properly and used for the purpose for which it is designed, except for the finish, which shall be free from visible peeling, or cracking or chalking under normal atmospheric conditions for a period of three (3) years, from the earlier of 1) the date the installation of the Product is completed, or 2) 30 days after the purchase of the Product by the original Purchaser (“Finish Warranty”). The Finish Warranty does not apply to any foreign residue deposited on the finish.

Galvanized coated sheet steel components will show rust on cut edges and is normal and will not affect the structure and function of the mount.

All installations in corrosive atmospheric conditions are excluded. The Finish Warranty is VOID if the practices specified by AAMA 609 & 610-02 – “Cleaning and Maintenance for Architecturally Finished Aluminum” ([www.aamanet.org](http://www.aamanet.org)) are not followed by Purchaser for Tamarack Solar’s aluminum based products.

The warranty covers the replacement cost of parts to repair the product to proper working condition. Transportation and incidental costs associated with warranty items are not reimbursable. The warranty does not cover normal wear, or damage resulting from misuse, abuse, improper installation, negligence, or accident, or typographical errors in instruction manuals. The Warranty does not cover any defect that has not been reported in writing to Tamarack Solar within ten (10) days after discovery of such defect. Furthermore, it does not cover units that have been altered, modified or repaired without written authorization from the manufacturer or its authorized representative, or units used in a manner or for a purpose other than that specified by the manufacturer. Tamarack Solar’s entire liability and Purchaser exclusive remedy, whether in contract, tort or otherwise, for any claim related to or arising out of breach of the warranty covering the Mounting Structures shall be correction of defects by repair, replacement, or credit, at Tamarack Solar’s discretion. Refurbished Mounting Structures may be used to repair or replace the Mounting Structures

Tamarack Solar shall have no liability for any injuries or damages to persons or property resulting from any cause, whatsoever, or any claims or demands brought against Tamarack Solar by Purchaser, any employee of Purchaser, client of Purchaser, end-user of the Product or other party, even if Tamarack Solar has been advised of the possibility of such claims or demands (collectively, “Third Party Claims”). This limitation applies to all materials provided by Tamarack Solar during and after the Warranty Period.